

# NordiCHI 2012

---

## Sponsoring and exhibiting at NordiCHI 2012

NordiCHI 2012 would like to offer you the possibility to sponsor, exhibit or give a company presentation in order to gain access to leading researchers and professionals in HCI.

### Attendance at NordiCHI 2012 will give you:

- **Exposure** – to the best researchers and students within the field of user experience design and in general as a company or organization that is a leading name in HCI.
- **Knowledge** – about the newest technology and research.
- **Possibilities** – of marketing your technology or method towards opinion leaders within the field.

### The types of sponsor and exhibiting packages are:

- **1X Platinum:** 10,000 EUR
- **2X Gold:** 5,000 EUR
- **VIP Exhibition with cocktail:** 3,750 EUR (+ cocktail expenses)
- **Large Exhibition:** 2,500 EUR
- **Small Exhibition:** 1,500 EUR
- **Leaflet + programme:** 630 EUR
- **Leaflet:** 300 EUR

### Why sponsor NordiCHI 2012?

This conference brings together leading researchers from academia and industry to build lasting relationships and explore new applications in human-computer interaction research. It provides an environment in which important issues and contrasting perspectives are discussed as part of an intensive 3-day programme. This event covers a wide range of leading edge methodologies that are either emergent or actively employed in HCI research today.

### Who will attend?

This exclusive event attracts 350 HCI professionals from innovative companies and universities to engage in a high-level exchange of ideas.

### What is NordiCHI?

NordiCHI is the main forum for human-computer interaction research. Since its inception in 2000, NordiCHI has brought together leading researchers and practitioners to exchange ideas, discuss new methods and review standard practices. The next conference will continue to offer a balance of academic and practitioner presentations, design cases, tutorials and workshops, aesthetic artefacts, and interactive demos. More information can be found on

[www.nordichi2012.org](http://www.nordichi2012.org)



## Sponsor Packages

The success of NordiCHI 2012 is highly dependent on the support of local and international sponsors. A sponsorship is an excellent opportunity to expose your company or organization as a leading name in HCI. NordiCHI 2012 offers several different levels of exposure, including the Platinum Conference Sponsorship, Gold Event Sponsorship and Exhibit package.

### Platinum Sponsor

Sponsors participating at NordiCHI 2012 at the Platinum level will receive maximum exposure:

- Special recognition with colour logo at opening plenary, closing plenary, conference dinner, and welcome reception
- Platinum Sponsor Thank You and Highlight on the NordiCHI 2012 web site
- Colour logo specially displayed on the NordiCHI 2012 web site with a link of your choice
- Prominent logo placement and recognition in Program Book
- Prominent recognition signage at Exhibit Hall entrance and social events
- Logo placement on conference signage
- Free premium location exhibit booth at the NordiCHI Expo
- 50% discount on additional booths
- 2 inserts in every attendee's packet
- 3 complimentary Conference Registrations
- Complimentary Job Recruiting Board

**Price: 10,000 EUR**

### Gold Sponsor of an event, Welcome reception and/or Conference dinner

Sponsors participating at NordiCHI 2012 at the Gold level will receive significant exposure:

- Recognition at one of described events (Welcome reception, Conference dinner)
- Event Sponsor Thank You and Highlight on the NordiCHI 2012 web site
- Colour logo specifically displayed on the NordiCHI 2012 web site with a link of your choice
- Logo placement and recognition in the Program Book
- Free premium location exhibit booth at the NordiCHI Expo
- 25% discount on additional booths
- 1 insert in every attendee's packet
- 1 complimentary Conference Registrations
- Complimentary Job Recruiting Board

**Price: 5,000 EUR (per event)**

## Exhibitors

- Exhibition space:
  - Small 3x2m (5 poster walls)
  - Large 3x4m (6 poster walls)
  - (includes poster walls, power outlet, table and 2 chairs)
- 1/2 full conference pass(es)
- Delegate pack with:
  - Electronic version of conference papers
  - List of participants
- Publication of company name on the NordiCHI 2012 website and in the printed Program Book

### Price for small booth: 1,500 EUR

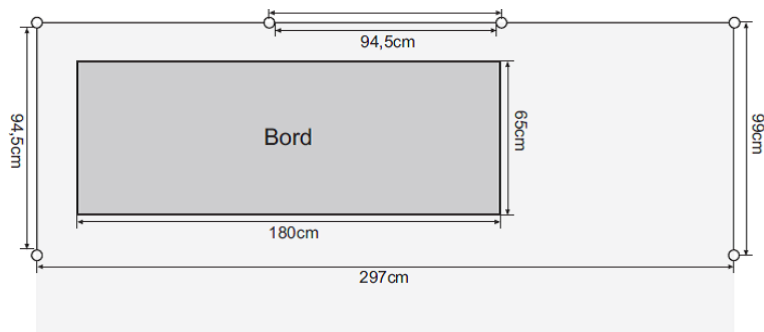

### Price for large booth: 2,500 EUR

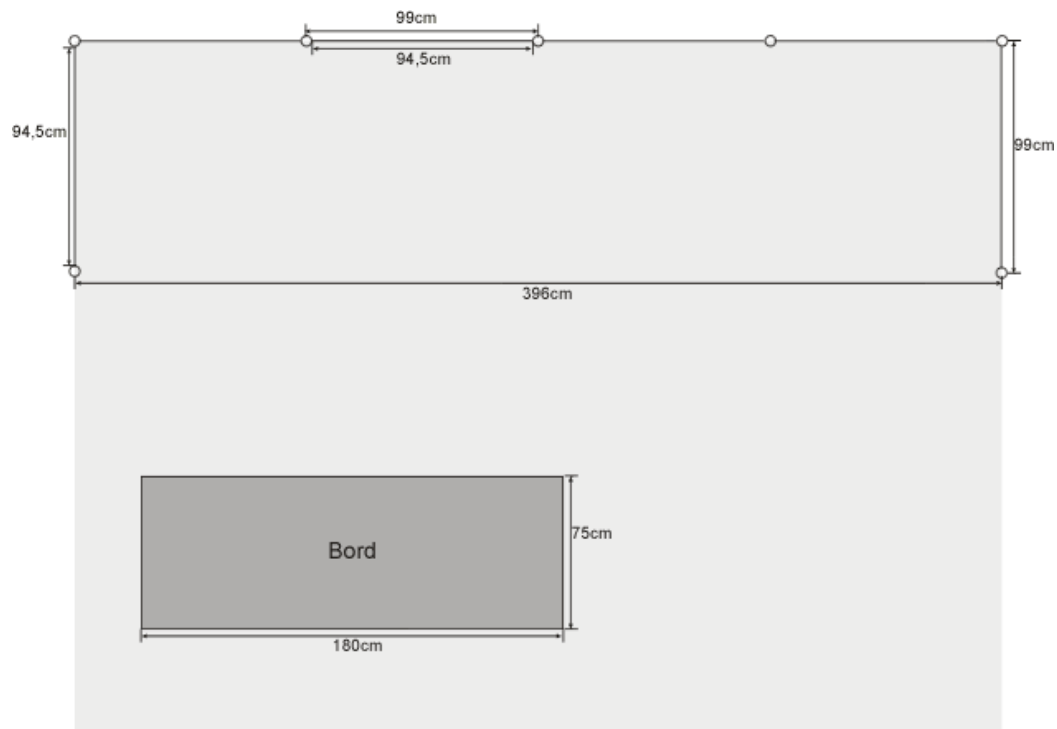

### **VIP Exhibitor with poster session cocktails**

- Exhibition space: Large 3x4m (includes 6 poster walls, power outlet, table and 2 chairs)
- 2 full conference passes
- Delegate pack with:
  - Electronic version of conference papers
  - List of participants
- Publication of company name on the NordiCHI 2012 website and in the printed Program Book
- Dedicated room for VIP-event with cocktail servings and displays

**Price: 3,750 EUR (+ expenses to cocktails)**

### **Advertising in the Program Book**

The Program Book will contain the conference program - an indispensable source of information for the participants of NordiCHI 2012, also after the conference. You can have your company or product advertisement in the Program Book of NordiCHI 2012. The advertisement is to be sent as a .jpg or .gif file to [sponsor@nordichi2012.org](mailto:sponsor@nordichi2012.org) before 1 June 2012.

**Price: 650 EUR**

### **Promotional Leaflet in the Conference Bag**

We offer you the possibility to have your promotional leaflet included in the Conference Bag, which includes the Program Book and will be handed to all participants. Leaflets or brochures (350 copies) have to be at the NordiCHI secretariat before 1 October 2012. (Postage not included)

**Price: 300 EUR**

### **Donations**

The Conference welcomes pre-approved donations of the following conference items from supporting

#### **Organizations:**

- Attendee Registration Bags
- Attendee Badge Holders
- or other items suggested by supporting organizations

All item production and shipment costs are the responsibility of the supporting organization.

**Please contact sponsor chair to coordinate.**

## Overview of sponsor and exhibiting packages

	Platinum	Gold	VIP-exhibitor	Exhibitor large booth	Exhibitor small booth	Programme + leaflet	Leaflet	Donations
<b>Price in EUR</b>	10,000	5,000	3,750	2,500	1,500	650	300	
<b>Website</b>	Top position on website	Highlight on website	Company name + logo	Company name + logo	Company name + logo			
	Colour Logo with link of your choice	Colour Logo with link of your choice						
<b>Programme</b>	Full pages with logo and text	Prominent placement of logo + text	On exhibitor list	On exhibitor list	On exhibitor list	½ page advertisement		Mentioning
<b>Physical Exposure</b>	Banner in exhibitor hall + keynote auditorium	Mentioned at sponsored event (welcome reception or conference dinner)	Dedicated room for event with cocktail servings and displays					
	Mentioning in Opening plenary, conference dinner, welcome reception, closing plenary							
<b>Participation</b>	3 entrees	2 entrees	2	2	1			
<b>Booth</b>	Premium position	Premium position	Large booth	Large booth	Small booth			
	50% discount on additional	25% discount on additional						
<b>Job recruiting board</b>	Free	Free	Free	Free				
<b>Leaflet</b>	2 inserts	1 inserts	1	1		1	1	